

Reading  
eggs

Between Year 1 and Year 2

# BACK ON TRACK

READING • WEEK 2

Get on Track  
for Year 2



[www.readingeggs.co.uk](http://www.readingeggs.co.uk)



## Welcome to Week 2

Welcome to Week 2 of your Back On Track literacy programme!

This programme is for students between Year 1 and Year 2. It reinforces the learning from Year 1 and provides the essential skills your child needs to transition successfully into Year 2.

Over 10 weeks, your child will have the opportunity to engage in fun-filled, online learning activities, based on the **Fast Phonics** programme. **Fast Phonics** uses the proven power of systematic synthetic phonics instruction to boost reading skills. It focuses on phonemic awareness and phonics practise.

Each week you'll receive a 20-page booklet. Inside you will find a set of carefully selected activity sheets that will allow your child to revisit, consolidate and build crucial reading and literacy skills. We've packed lots in so your child can get excited for Year 2!

We recommend you follow these simple steps to get the most out of the 10-week programme.

- 1 Print the pupil pages for the week. Ensure your child has pencils and erasers to complete the worksheets.
- 2 Start by setting your child up on **Fast Phonics**. Activities begin at **Peak 15** and allow your child to progress at their own pace.
- 3 Encourage your child to read the recommended books from the **Reading Eggspress** library.
- 4 Once each day's work is complete, fill in the incentive chart. There is also a certificate at the end of the week to celebrate your child's achievement.
- 5 Enjoy the learning. Keep it light.

We know your child will enjoy learning with **Fast Phonics** because it makes learning to read fun!



# Back On Track for Year 2

## Week 2

### Reading skills focus

- Hear and identify the sounds **ay, ie, ea, oy, ir** and match each sound to its letters.
- Practise breaking a word into its sounds, then blend the sounds to read the word.
- Build reading comprehension skills.
- Read and write the word **please**.

### Online

#### Fast Phonics Peak 15

- Letters and sounds focus: **ay, ie, ea, oy, ir**
- Split a word into its sounds for spelling.
- Read high frequency and tricky words – **being, called, comes, could, looked, Mr, Mrs, myself, often, or, other, please, people, should, would**
- Fast recall of the words: **away, bay, bird, boy, clay, could, crayon, day, dirt, first, girl, heap, joy, looked, Mr, Mrs, play, please, read, say, should, skirt, stay, third, today, toy, tray, would**
- Read 3 books and answer questions to build comprehension.

### Worksheets

**Day 1:** Letters **ay**; Letters **ie**

**Day 2:** Middle and end sounds; Letters **ea**

**Day 3:** Letters **oy**; Middle and end sounds

**Day 4:** Letters **ir**; Word **please**

**Day 5:** Missing words; Read. Draw. Write.

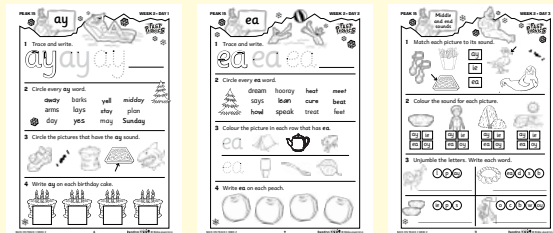

### Bonus pages

- oy
- ir
- Crossword
- Reading record *Beach clean-up*

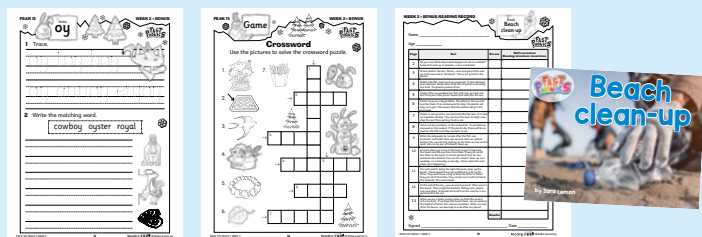

### Additional Reading Eggspress library books

1 Go to Library

2 Search for titles

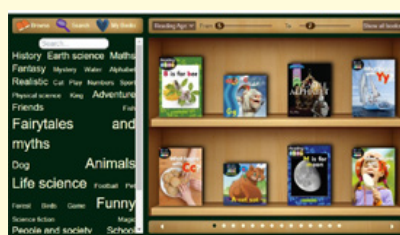

These books cover additional sounds

- *Neat and Clean*
- *Skipper Kipper*
- *Foxes*
- *The Frog in the Well*

ay



crayons

ie



tie

ea

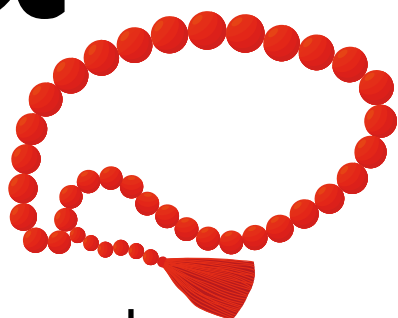

beads

oy



boy

ir



girl







# Week 2





## Incentive chart for:

\_\_\_\_\_

Colour each one when you have completed each day's work.

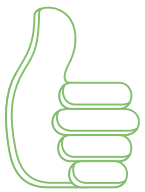
Week 2	Monday	Tuesday	Wednesday	Thursday	Friday
Online Lesson	Peak 15	Peak 15	Peak 15	Peak 15	End of Peak 15 Quiz

Worksheets					
------------	------------------------------------------------------------------------------------	------------------------------------------------------------------------------------	-------------------------------------------------------------------------------------	--------------------------------------------------------------------------------------	--------------------------------------------------------------------------------------

Day Done!					
-----------	-------------------------------------------------------------------------------------	-------------------------------------------------------------------------------------	-------------------------------------------------------------------------------------	---------------------------------------------------------------------------------------	---------------------------------------------------------------------------------------

Notes/thoughts/ideas

---

---

---

---

---

---

---

---

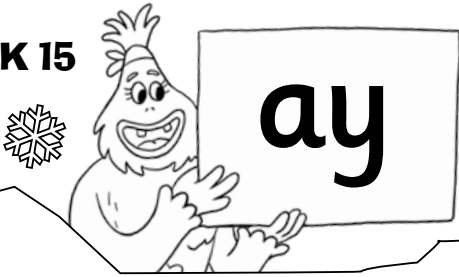

**FAST  
PHONICS**

1 Trace and write.



2 Circle every **ay** word.

away      barks      yell      midday  
 arms      lays      stay      plan  
 day      yes      may      Sunday

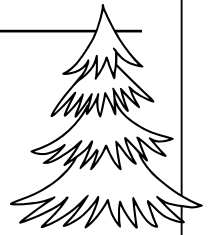

3 Circle the pictures that have the **ay** sound.

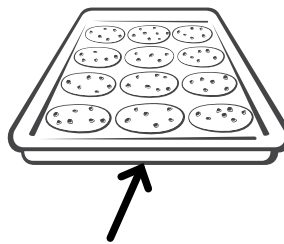

4 Write **ay** on each birthday cake.

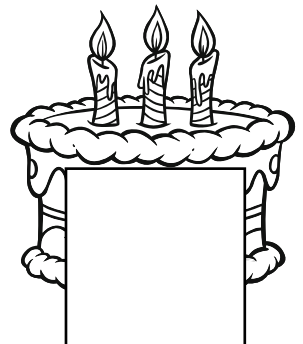
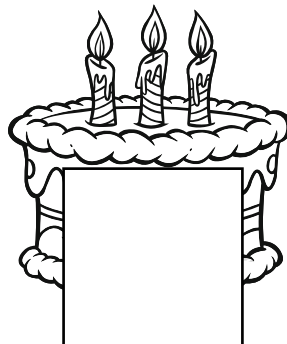
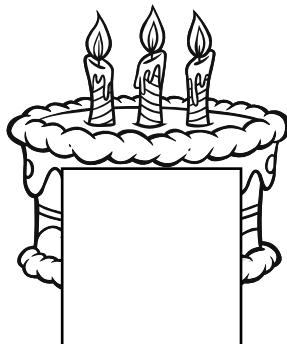
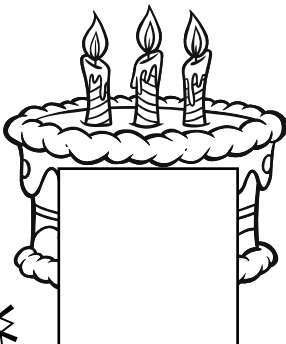

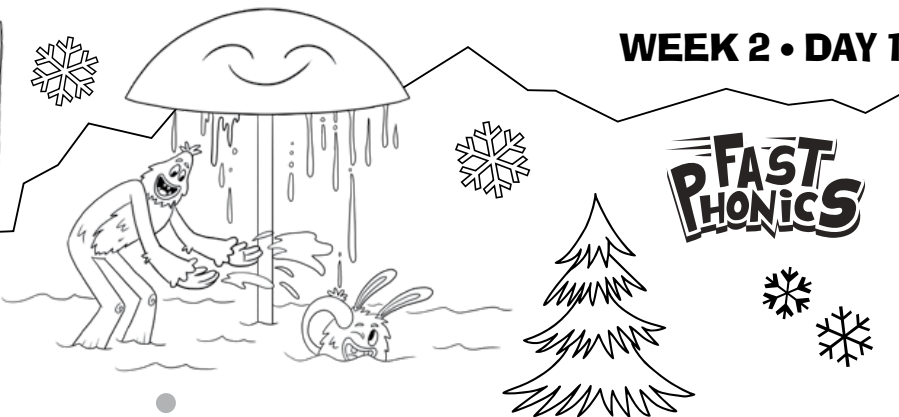
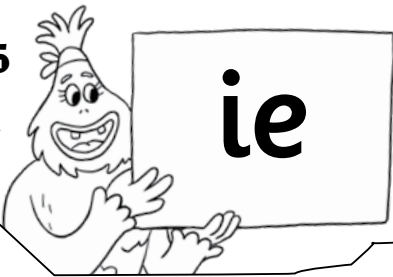

**FAST  
PHONICS**

**1** Trace and write.



**2** Circle every **ie** word.

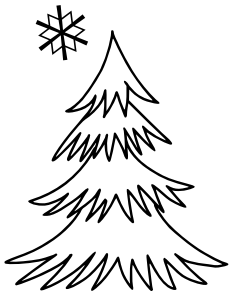

<i>lie</i>	clay	replies	ties
trays	pies	tries	feet
skies	flies	bowl	spies

**3** Match the pictures that have **ie**.



**ie**

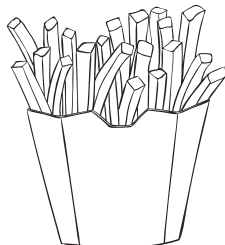

**4** Write **ie** on every pie.

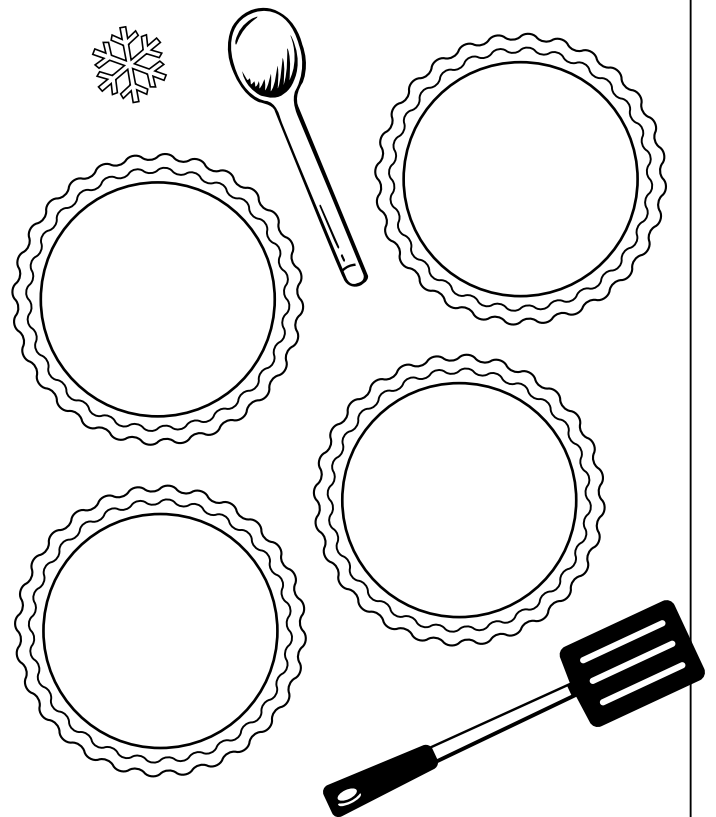



Middle and end sounds

FAST PHONICS

1 Match each picture to its sound.

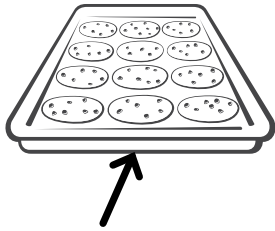

ay

ie

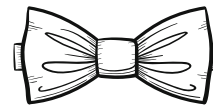

2 Complete each word.

ay

ie



pl\_\_\_\_\_



cr\_\_\_\_\_s

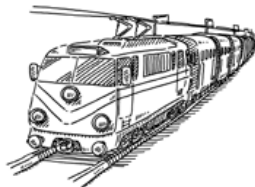

railw\_\_\_\_\_

3 Write the words in the correct boxes.

birthday bay magpie plays lies fries

ay

ie



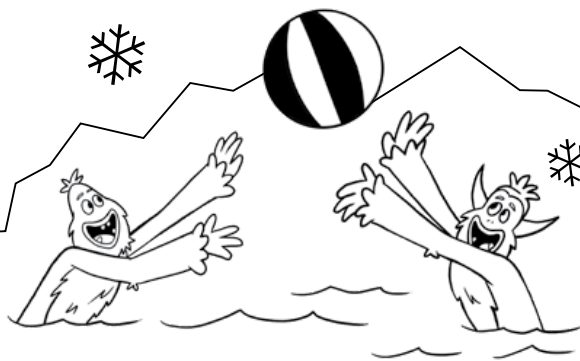

**FAST  
PHONICS**

1 Trace and write.

ea ea ea \_\_\_\_\_

2 Circle every ea word.

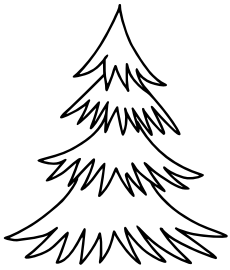

dream hooray heat meet  
says lean cure beat  
howl speak treat feet

3 Colour the picture in each row that has ea.

ea



ea



4 Write ea on each peach.



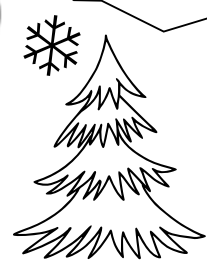
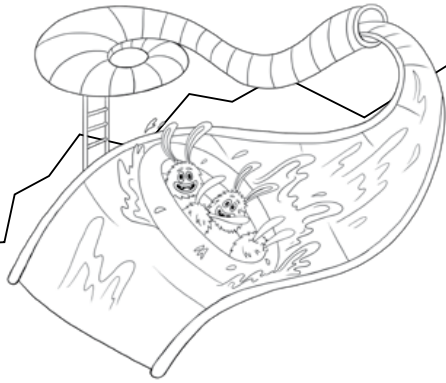
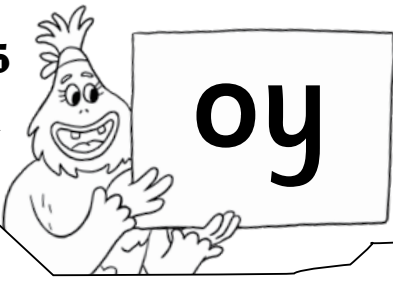

**FAST  
PHONICS**

**1** Trace and write.

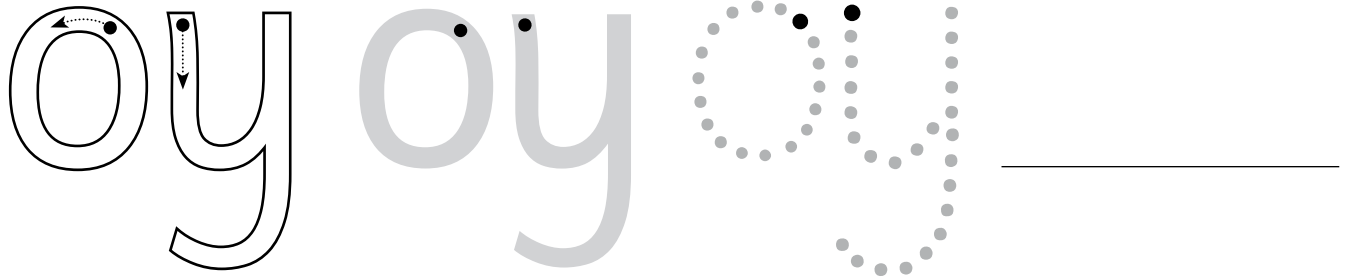

**2** Circle every oy word.



stay

cries

annoy

fond

flies

enjoy

stay

boy

royal

toy

goat

speak

**3** Match the pictures that have oy.



oy



**4** Write oy on each toy box.

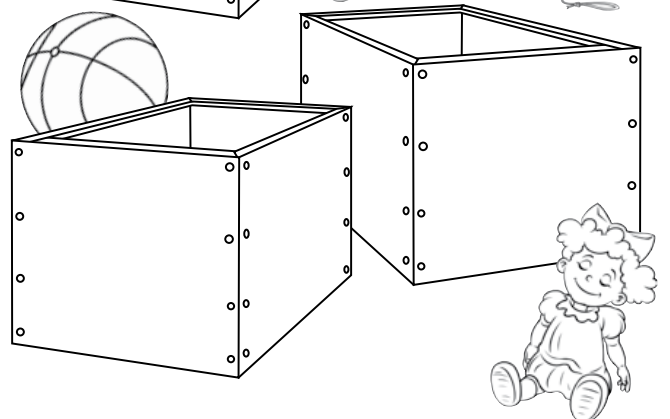
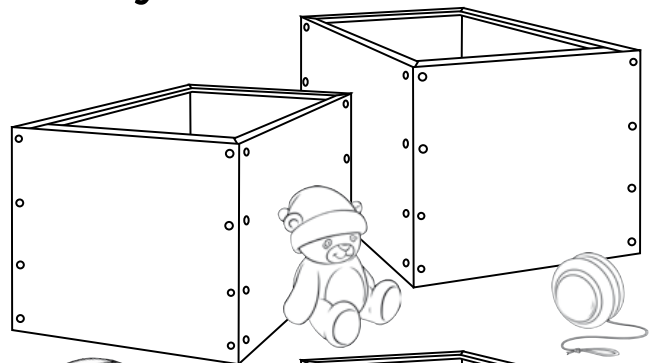

1 Match each picture to its sound.

ay

ie

ea

2 Colour the sound for each picture.

ay ie

ea oy

ay ie

ea oy

ay ie

ea oy

ay ie

ea oy

3 Unjumble the letters. Write each word.

l p ay

\_\_\_\_\_

ea d s b

\_\_\_\_\_

ie p s

\_\_\_\_\_

o c b w oy

\_\_\_\_\_

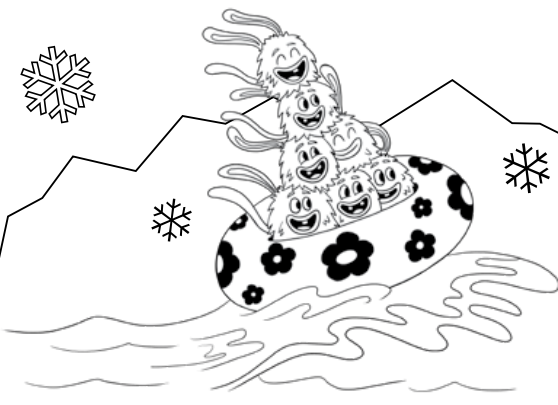
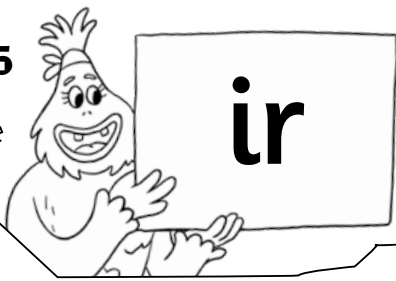

FAST PHONICS

1 Trace and write.

ir ir ir



2 Circle every ir word.



chip

harm

cork

dirt

hear

sir

twirl

farm

first

creek

tries

fir

3 Colour the picture in each row that has ir.

ir

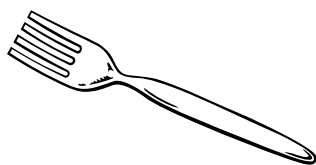

ir



4 Write ir on each T-shirt.

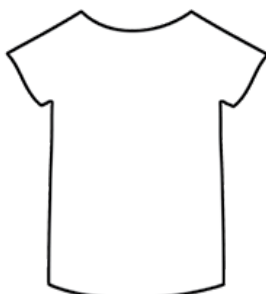
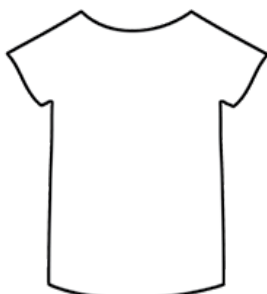

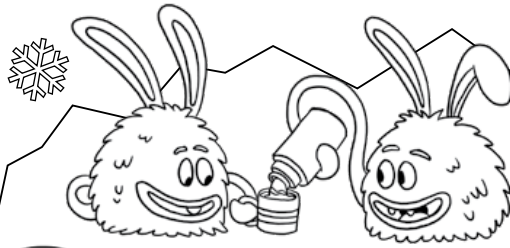
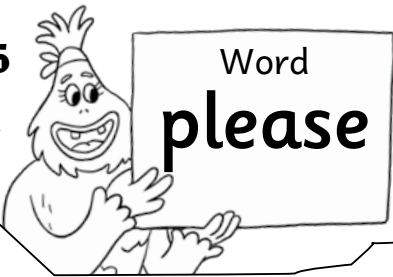

**FAST PHONICS**

1 Make a rainbow  word.



please

2 Read please 3 times.

please

please

please

3 Circle every please.

p	l	e	a	s	e	l	p	s
l	p	l	e	a	s	e	l	p
e	p	l	p	l	e	a	s	e
p	l	p	l	e	a	s	e	p

4 Copy.

Please may I speak?



# Missing words



# FAST PHONICS



1 Read each sentence. Write the missing words.



people  
 seabirds  
 clean  
 sure  
 each  
 beach

You will need to bring the right things to \_\_\_\_\_ up the \_\_\_\_\_.

These \_\_\_\_\_ have got grabbers to pick up the litter.

They \_\_\_\_\_ have a bag to drop the litter in. When they get rid of the litter, they can be \_\_\_\_\_ it will not harm the \_\_\_\_\_, fish and animals.





Read.  
Draw.  
Write.

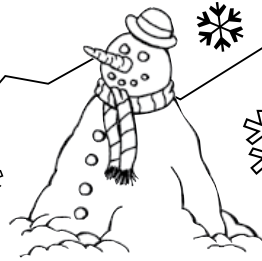

FAST  
PHONICS



**1** Read the words. **2** Draw the picture.

The girl enjoys peach pie and cream.

Large empty rectangular box for drawing.

**3** Look at the picture. Write a sentence.

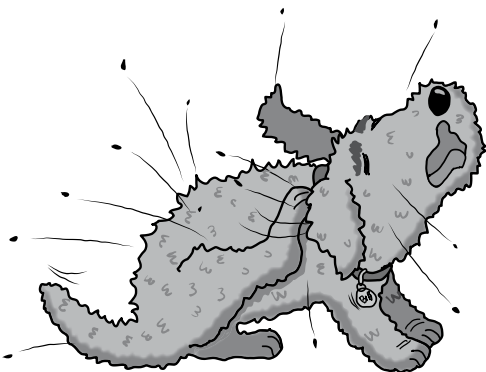

Two horizontal lines for writing a sentence.

Horizontal line for writing.

Horizontal line for writing.





Write  
**oy**

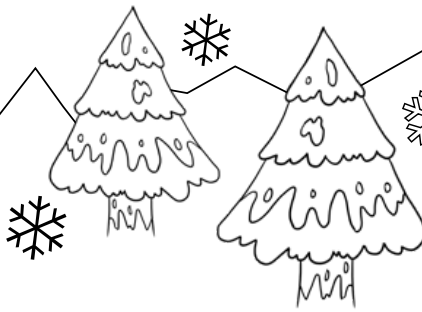

**FAST  
PHONICS**

**1** Trace.

oy oy oy oy oy oy oy oy oy oy

oy oy oy oy oy oy oy oy oy oy



**2** Write the matching word.

cowboy oyster royal

\_\_\_\_\_

\_\_\_\_\_

\_\_\_\_\_

\_\_\_\_\_

\_\_\_\_\_

\_\_\_\_\_

\_\_\_\_\_

\_\_\_\_\_

\_\_\_\_\_

\_\_\_\_\_

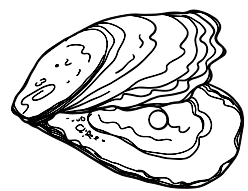
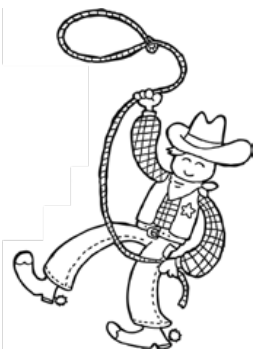





Write

ir



FAST PHONICS



1 Trace and write.

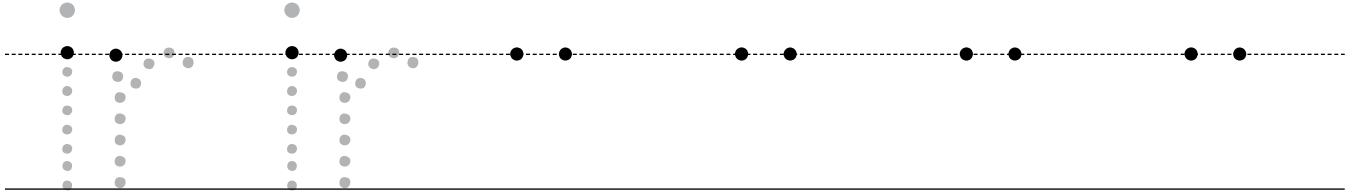

2 Copy. Draw a picture.



The girl hears a little bird chirp.

Handwriting practice lines consisting of solid top and bottom lines with a dashed middle line for copying the text.

A large empty rectangular box for drawing a picture related to the sentence above.



Game

FAST PHONICS

# Crossword

Use the pictures to solve the crossword puzzle.

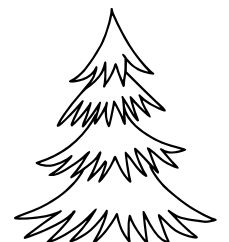
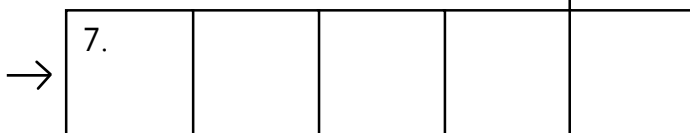
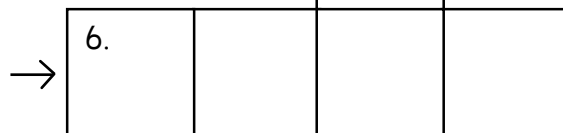
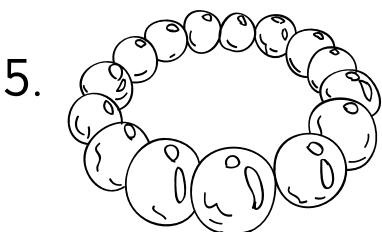
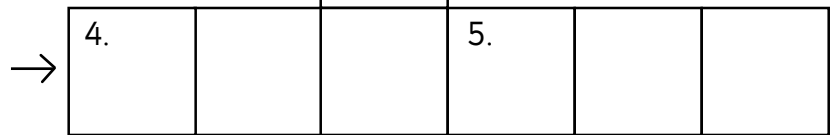
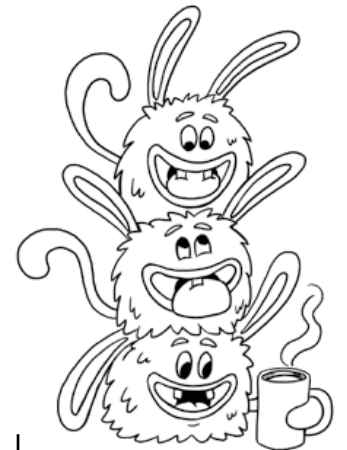
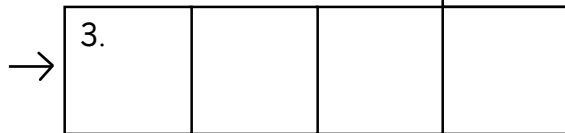
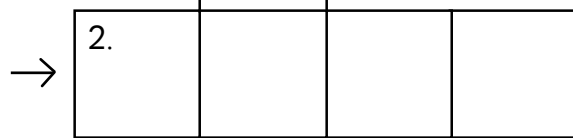
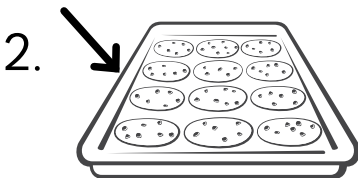
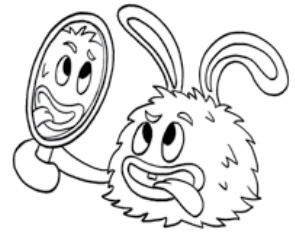
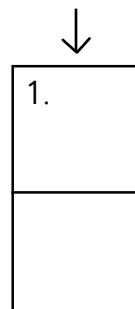
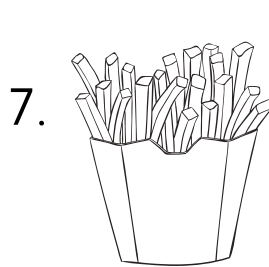

# WEEK 2 • BONUS READING RECORD



Book  
**Beach  
clean-up**



**FAST  
PHONICS**

Name \_\_\_\_\_

Age \_\_\_\_\_

Page	Text	Errors	Self-correction Meaning/structure/visual clues
2	Do you ever think about what happens to all our rubbish? Some of it ends up in streams, rivers and drains.		
3	Drains lead to the sea. Plastic, cans and glass often end up in the sea and on the beach. This is not good for the planet.		
4	Plastic kills fish, birds and sea mammals. It also destroys their habitats. Birds often think bits of plastic and string are food. The plastic poisons them.		
5	Plastic litter is a problem for fish. Fish may get sick and die if they eat little plastic beads that leak into the sea.		
6	Plastic bags are a big problem. They float in the sea and look like food. If an animal eats the bag, the plastic will stay in its gut. This means that the animal will get sick and weak.		
7	Plastic is not good for sea mammals like this seal. It is tied up in plastic netting. This can hurt the seal. It might also stop the seal from getting food to eat.		
8	Litter can be a problem on the seabed too. It can destroy seaweed on the seabed. If the plants die, there will be no food for the fish and other animals to eat.		
9	What should people do to look after the fish, sea mammals and birds? How can we look after our planet better? We can start by picking up the litter we see on the sand. We can be part of a beach clean-up.		
10	A beach clean-up is one of the best ways to help keep the beach and the sea free from litter. If we pick up all the litter on the sand, it cannot get back into the sea and harm the animals. You can do a beach clean-up on a weekday, or a Saturday or Sunday. Check when the next clean-up is happening.		
11	You will need to bring the right things to clean up the beach. These people have got grabbers to pick up the litter. They each have a bag to drop the litter in. When they get rid of the litter, they can be sure it will not harm the seabirds, fish and animals.		
12	At the end of the day, you can see how much litter was on the beach. There might be buckets, fishing nets, plastic, cans and glass. It should not be left on the sand as it can get back into the sea.		
13	When we are a team, picking litter up from the sand is not a hard job. If we keep the beach clean, we can protect the habitat of birds, fish and sea mammals. When we look after the beach, we also help to look after our planet.		



**Results**

Signed \_\_\_\_\_ Date \_\_\_\_\_



# WHEEEEEEE!

It's time for  
Week 3!



[www.readingeggs.co.uk](http://www.readingeggs.co.uk)

