

Between Grades 1 and 2

SUMMIEIR



Mathseeds

Math Catch-up

Week 3

Breeze
through to
Grade 2

www.mathseeds.com



Welcome to Week 3

Fluency in operations – addition, subtraction, multiplication, and division – is an essential mathematical building block.

Math fact fluency is the ability to automatically recall basic math facts, including number bonds to 10 or 20, their subtractive opposites, the times tables and related division facts. There are four elements of fluency: flexibility, appropriate strategy use, efficiency, and accuracy. These elements differentiate math fact fluency from traditional rote learning.

Improvements in this area flow through to all other math lessons. Students who know their number facts are more confident and engaged mathematicians. This week we begin to suggest levels for your child to complete in our math fact fluency section: **Mental Minute**.

The **Mathseeds** lessons teach concepts and strategies for operations and give children plenty of opportunities to practice their skills. However, the **Mental Minute** section is purely focused on developing fluency with math facts. It provides regular practice for short periods of time – a key to developing math fact fluency.

The **Mathseeds Mental Minute Sprints** are a powerful tool to improve math fact fluency. In one minute, students focus on one set of math facts and are motivated to improve their score to earn badges. They can only do this by improving both their speed and accuracy. The **Mental Minute** online format is fun, full of rewards and, most importantly, easy to play.

- 145 carefully sequenced sprints.
- All students start from the beginning to ensure complete fact mastery.
- As students make progress, the question sets become more challenging.
- Each **Mental Minute** set takes one minute to complete.
- Each new set includes new questions while also revising previous facts.
- Students will be motivated to earn the colorful badges as they build number fact fluency.
- With one-, two-, and three-star levels to earn, students are focused and challenged to improve their instant recall of essential math facts.

Encourage your child to earn a badge or two every time they log in to **Mathseeds**.

This booklet is the third of ten weekly booklets you will receive over the summer break. The **Mathseeds** summer catch up program provides a great way to make sure that your child knows the essentials they need to make a successful transition into Grade 2. We know your child will enjoy learning on **Mathseeds** because **Mathseeds** makes learning fun – and that's what summer is all about!

Get Ready for Grade 2

Week 3

Day 1 focus: Sharing

Online lesson: Lesson 71 – Sharing 1

Worksheets: Share Equally, Draw and Write

Day 2 focus: Doubles

Online lesson: Lesson 72 – Doubles to Double 10

Worksheets: Count Doubles, Add Doubles

Day 3 focus: Mass

Online lesson: Lesson 73 – Mass

Worksheets: Balance Scales, Scales are Balanced

Day 4 focus: Grouping

Online lesson: Lesson 74 – Grouping

Worksheets: Counting Groups, Making Groups

Day 5 focus: Numbers 40–50

Online lesson: Lesson 75 – Counting 40-50

Worksheets: Order Numbers, Number Sense

Week 3 Bonus

Poster: Doubles

Online: Mental Minute + – Badge 89

Sheets: Sharing Fish, Doubling, How Many Pencils?

Hands-on: Estimation Mission



Doubles



● + ●

$1 + 1 = 2$

● ● + ● ●

$2 + 2 = 4$

● ● ● + ● ● ●

$3 + 3 = 6$

● ● ● ● + ● ● ● ●

$4 + 4 = 8$

● ● ● ● ● + ● ● ● ● ● ●

$5 + 5 = 10$

● ● ● ● ● ● + ● ● ● ● ● ●

$6 + 6 = 12$

● ● ● ● ● ● + ● ● ● ● ● ●

$7 + 7 = 14$

● ● ● ● ● ● + ● ● ● ● ● ●

$8 + 8 = 16$

● ● ● ● ● ● + ● ● ● ● ● ●

$9 + 9 = 18$





● ● ● ● ● ● + ● ● ● ● ● ●





$10 + 10 = 20$





Week 3

Incentive chart for:

Color each one when you have completed each day's work.

Week 3	Monday	Tuesday	Wednesday	Thursday	Friday
Online Lesson	 71	 72	 73	 74	 75

Worksheets					
------------	--	--	---	--	--

Day Done!					
-----------	---	---	---	---	---

Notes/thoughts/ideas

1 Share equally.

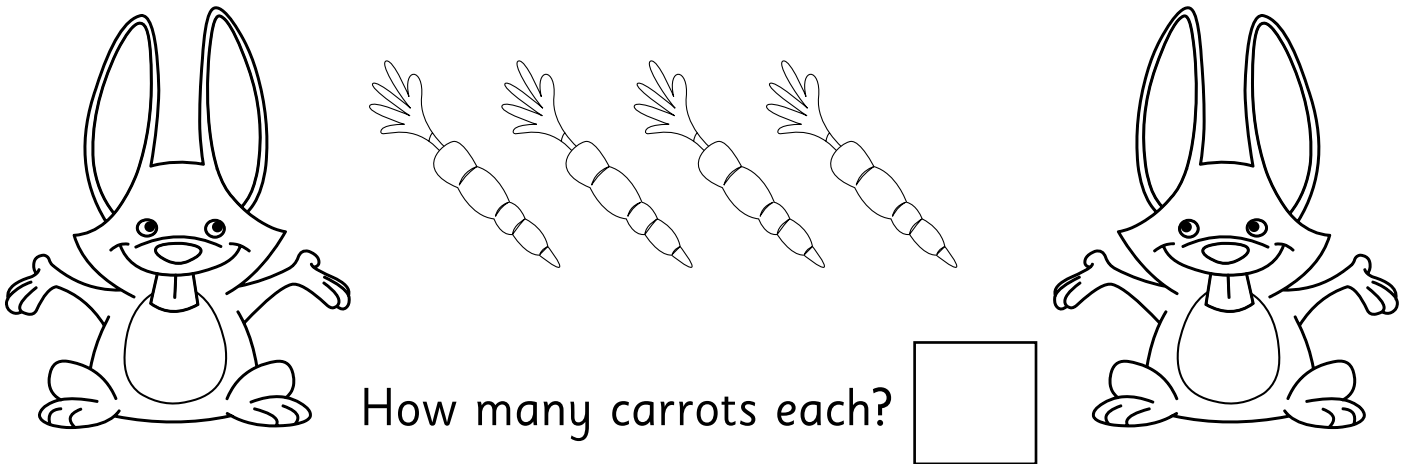

2 Share.

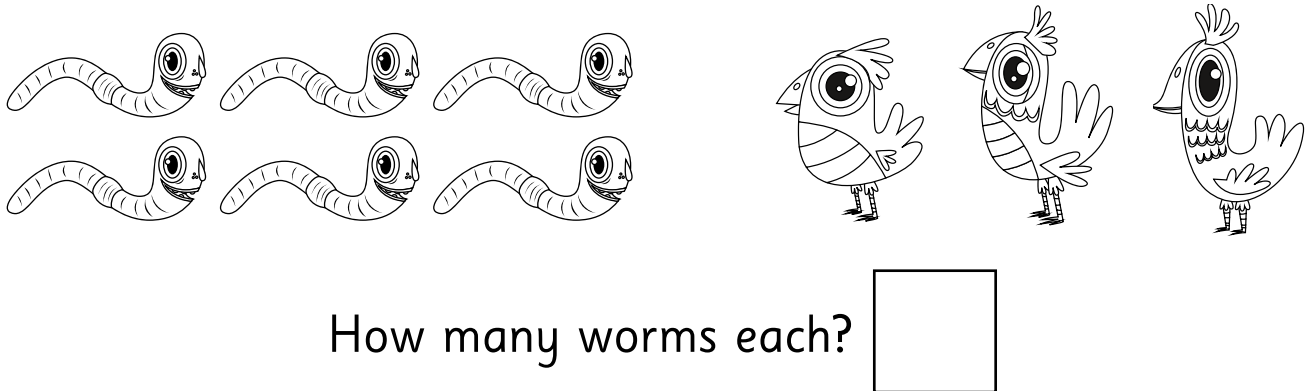

3 Draw lines to share the seeds equally.
How many seeds in each pot?

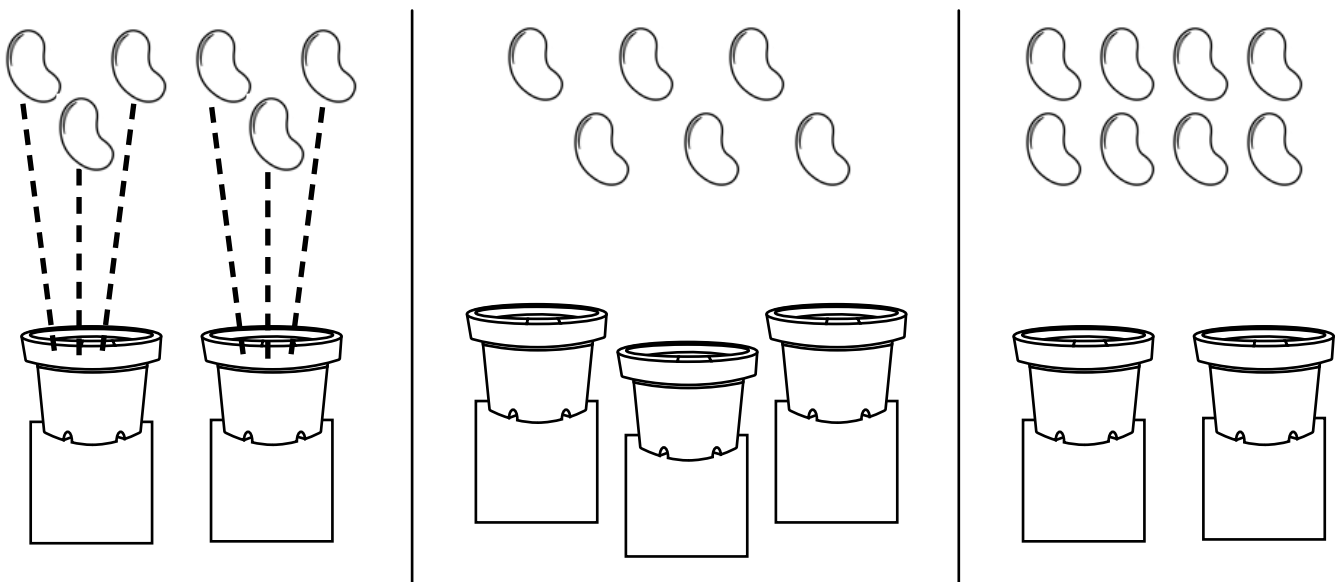

Find the answer. Show your working.

1 Share the sheep equally between 2 fields.

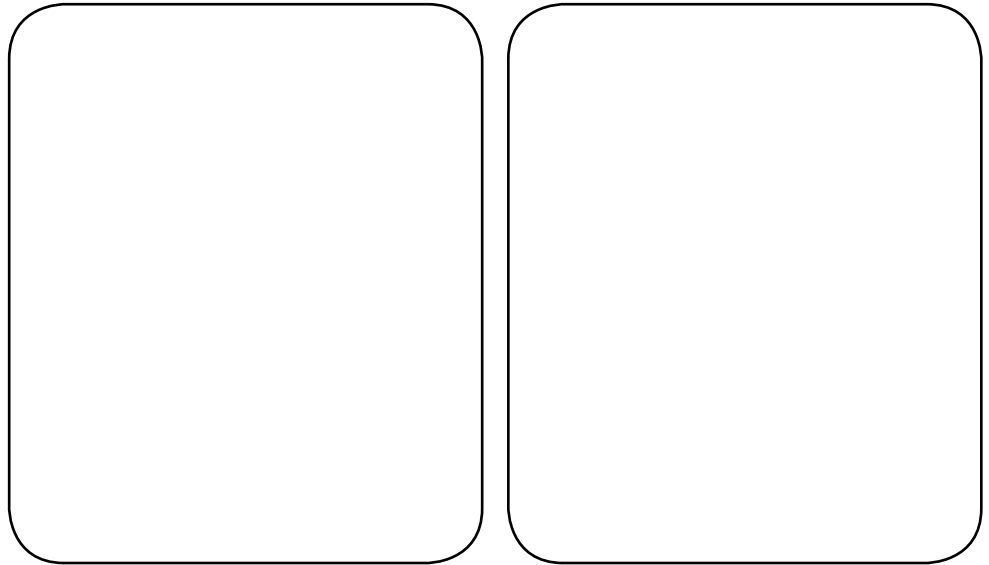
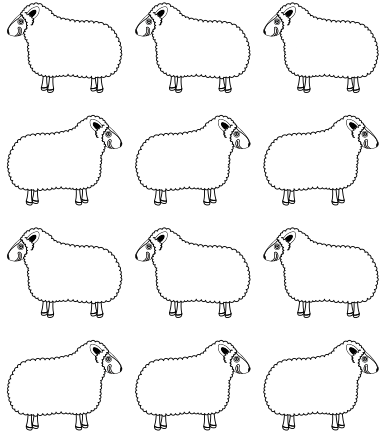

sheep shared between fields is each.

2 Share equally.

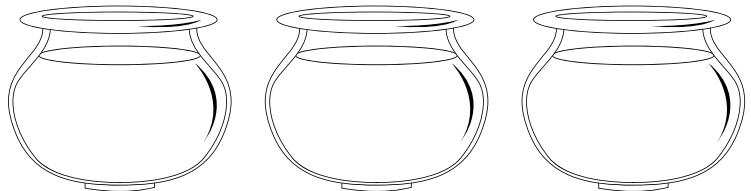
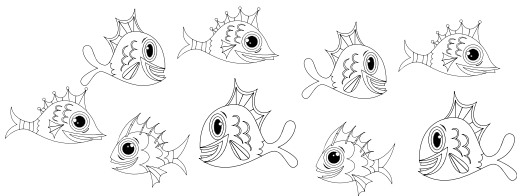

fish shared between bowls is each.

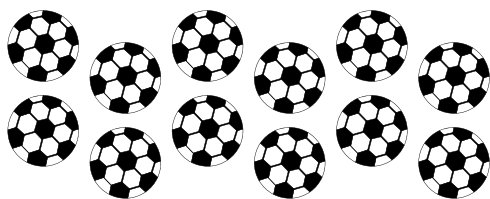

balls shared between children is each.

1 Draw matching spots. Write the answers.

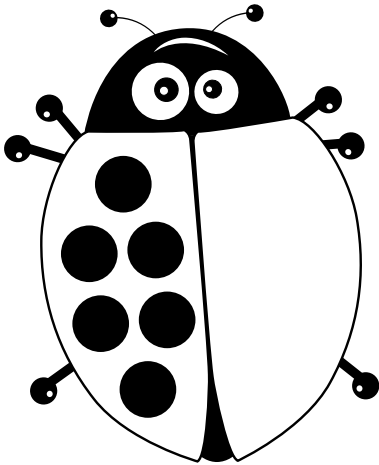

Double 6 is

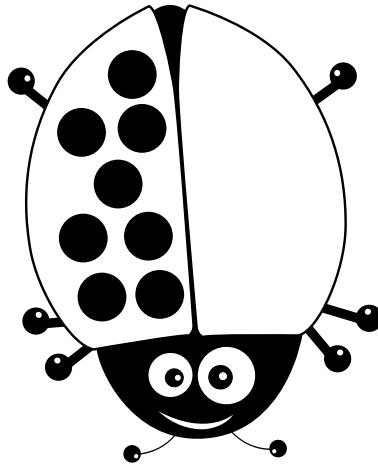

Double 8 is

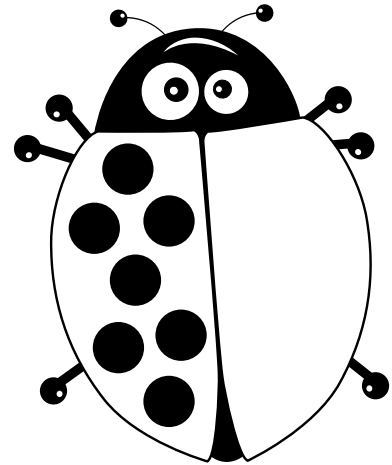

Double 7 is

2 Write the answers.

$$\begin{array}{|c|} \hline \bullet \\ \hline \end{array} + \begin{array}{|c|} \hline \bullet \\ \hline \end{array} = \begin{array}{|c|} \hline \\ \hline \end{array}$$

$$\begin{array}{|c|} \hline \bullet \\ \bullet \\ \hline \end{array} + \begin{array}{|c|} \hline \bullet \\ \bullet \\ \hline \end{array} = \begin{array}{|c|} \hline \\ \hline \end{array}$$

$$\begin{array}{|c|} \hline \bullet \bullet \\ \bullet \bullet \\ \hline \end{array} + \begin{array}{|c|} \hline \bullet \bullet \\ \bullet \bullet \\ \hline \end{array} = \begin{array}{|c|} \hline \\ \hline \end{array}$$

$$\begin{array}{|c|} \hline \bullet \\ \bullet \bullet \\ \hline \end{array} + \begin{array}{|c|} \hline \bullet \\ \bullet \bullet \\ \hline \end{array} = \begin{array}{|c|} \hline \\ \hline \end{array}$$

$$\begin{array}{|c|} \hline \bullet \bullet \\ \bullet \\ \bullet \bullet \\ \hline \end{array} + \begin{array}{|c|} \hline \bullet \bullet \\ \bullet \\ \bullet \bullet \\ \hline \end{array} = \begin{array}{|c|} \hline \\ \hline \end{array}$$

$$\begin{array}{|c|} \hline \bullet \bullet \bullet \\ \bullet \bullet \bullet \\ \hline \end{array} + \begin{array}{|c|} \hline \bullet \bullet \bullet \\ \bullet \bullet \bullet \\ \hline \end{array} = \begin{array}{|c|} \hline \\ \hline \end{array}$$

$$\begin{array}{|c|} \hline \bullet \bullet \bullet \\ \bullet \bullet \bullet \\ \hline \end{array} + \begin{array}{|c|} \hline \bullet \bullet \bullet \\ \bullet \bullet \bullet \\ \hline \end{array} = \begin{array}{|c|} \hline \\ \hline \end{array}$$

$$\begin{array}{|c|} \hline \bullet \bullet \\ \bullet \bullet \bullet \\ \hline \end{array} + \begin{array}{|c|} \hline \bullet \bullet \\ \bullet \bullet \bullet \\ \hline \end{array} = \begin{array}{|c|} \hline \\ \hline \end{array}$$

$$\begin{array}{|c|} \hline \bullet \bullet \bullet \\ \bullet \bullet \bullet \\ \hline \end{array} + \begin{array}{|c|} \hline \bullet \bullet \bullet \\ \bullet \bullet \bullet \\ \hline \end{array} = \begin{array}{|c|} \hline \\ \hline \end{array}$$

$$\begin{array}{|c|} \hline \bullet \bullet \\ \bullet \bullet \\ \hline \end{array} + \begin{array}{|c|} \hline \bullet \bullet \\ \bullet \bullet \\ \hline \end{array} = \begin{array}{|c|} \hline \\ \hline \end{array}$$

Write the missing numbers.

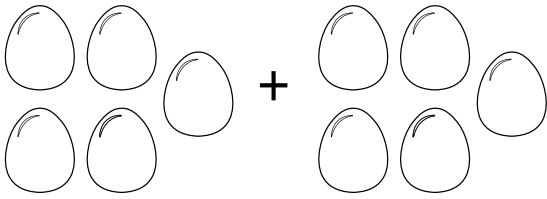

+

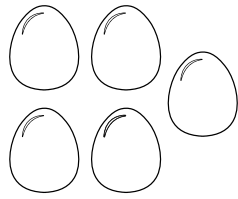

$$5 + 5 =$$



+



$$+ 6 =$$



+

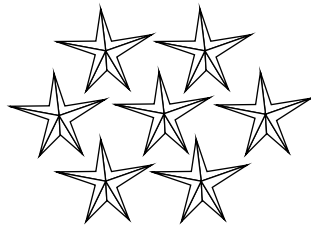

+

$$= 14$$

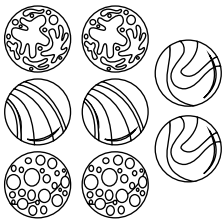

+

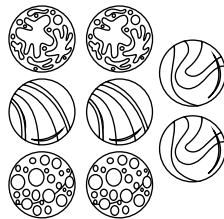

+

$$= 16$$

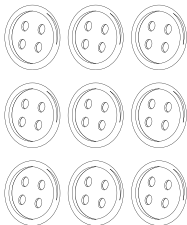

+

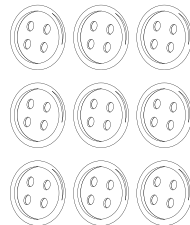

$$9 +$$

+

$$= 18$$

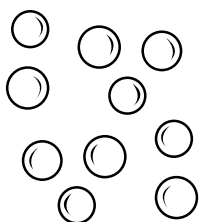

+

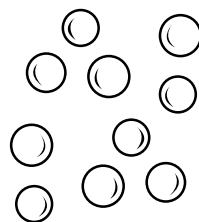

+

=

1 Circle.

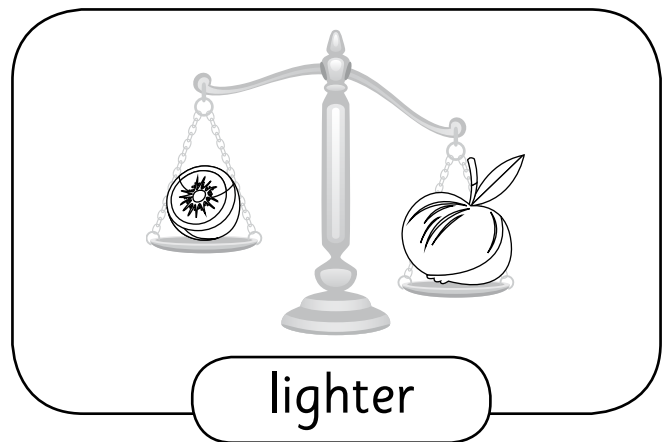
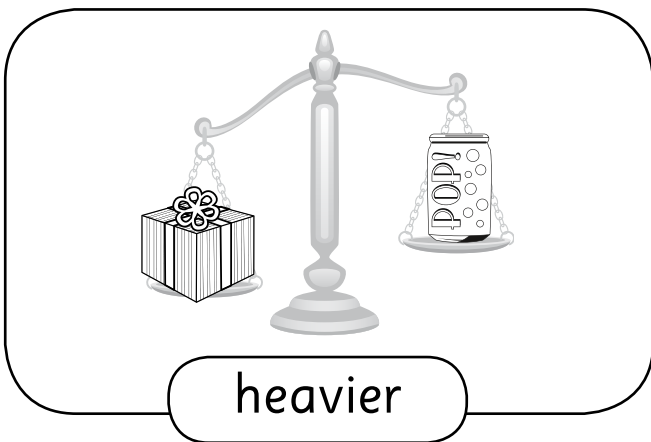
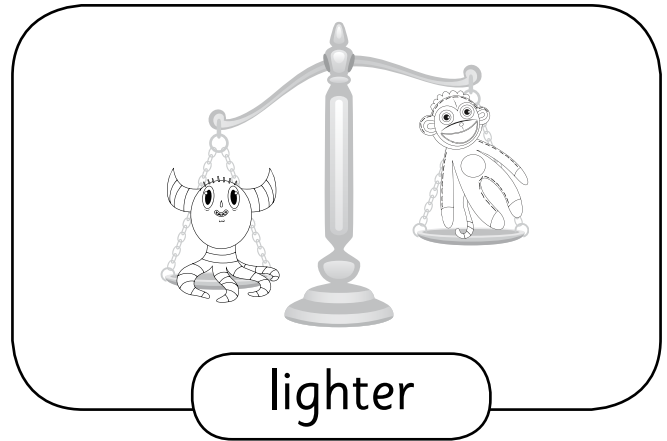
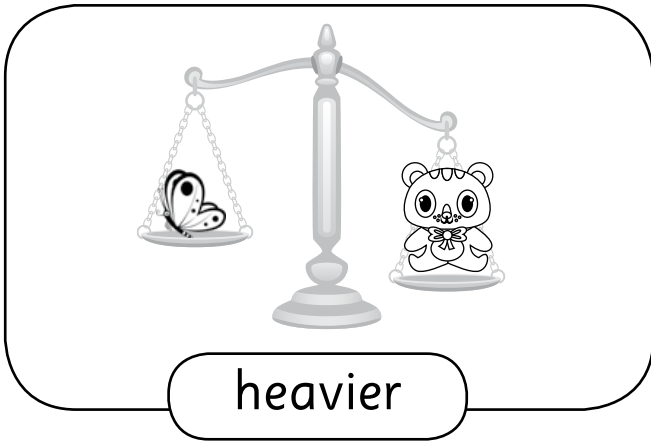

2 Draw the items on the scales.

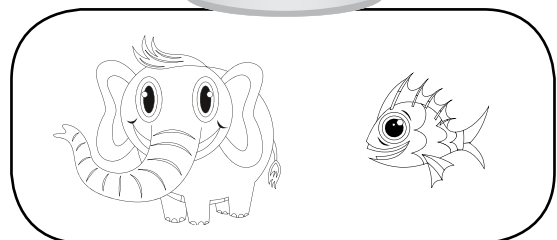
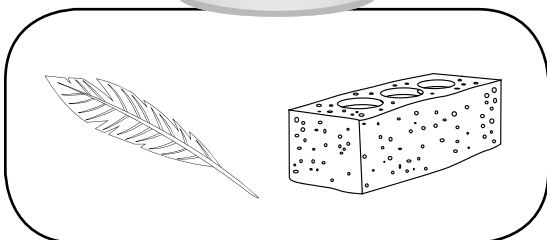

1 Color the scales that are balanced.

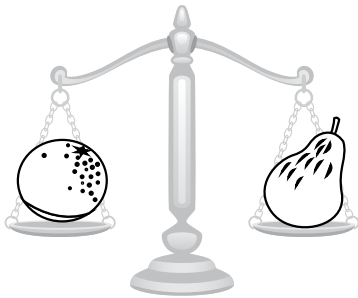
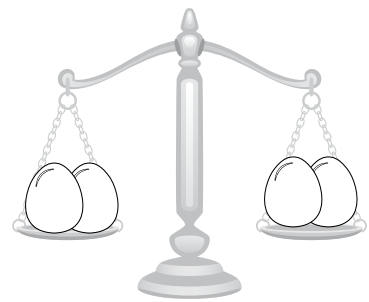

2 Draw things on the scales that you think will balance.



1 Circle groups of 2.

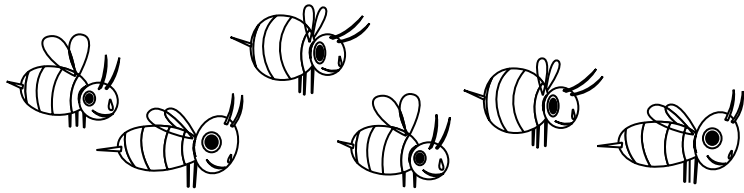

How many groups?

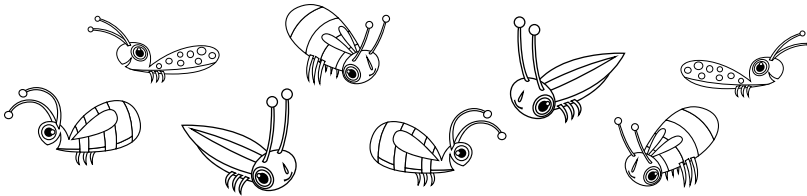

How many groups?

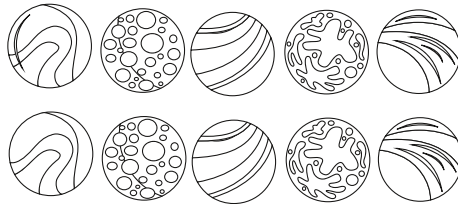

How many groups?

2 Count.

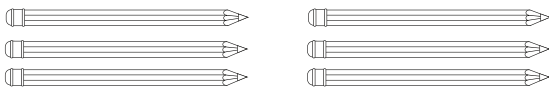

groups of pencils

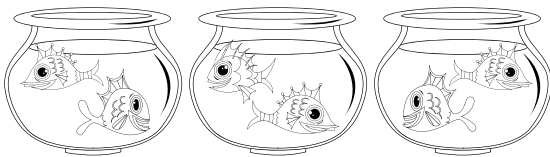

groups of fish

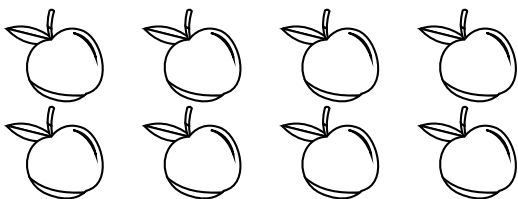

groups of apples

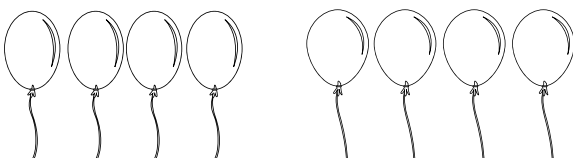

groups of balloons

1 Make 4 groups. Color 5 red, 5 yellow, 5 green, 5 orange.

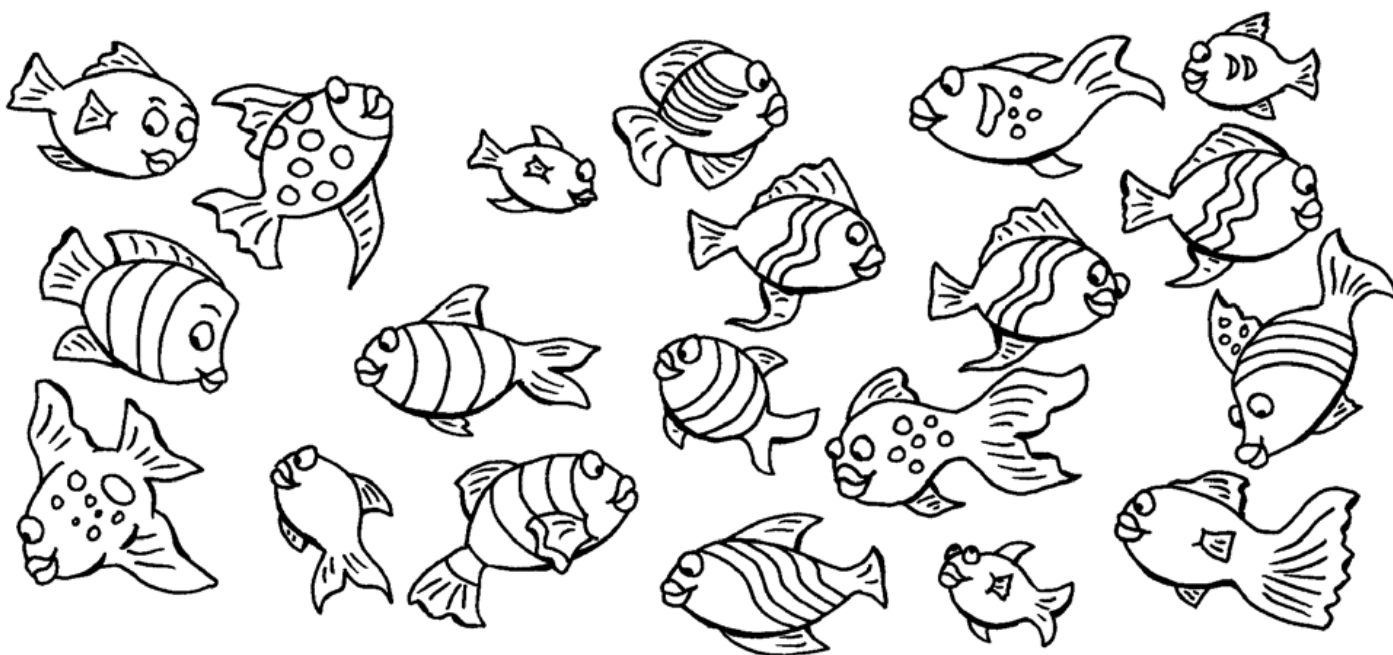

Complete. 4 groups of 5 fish is altogether.

2 Circle groups of 3.

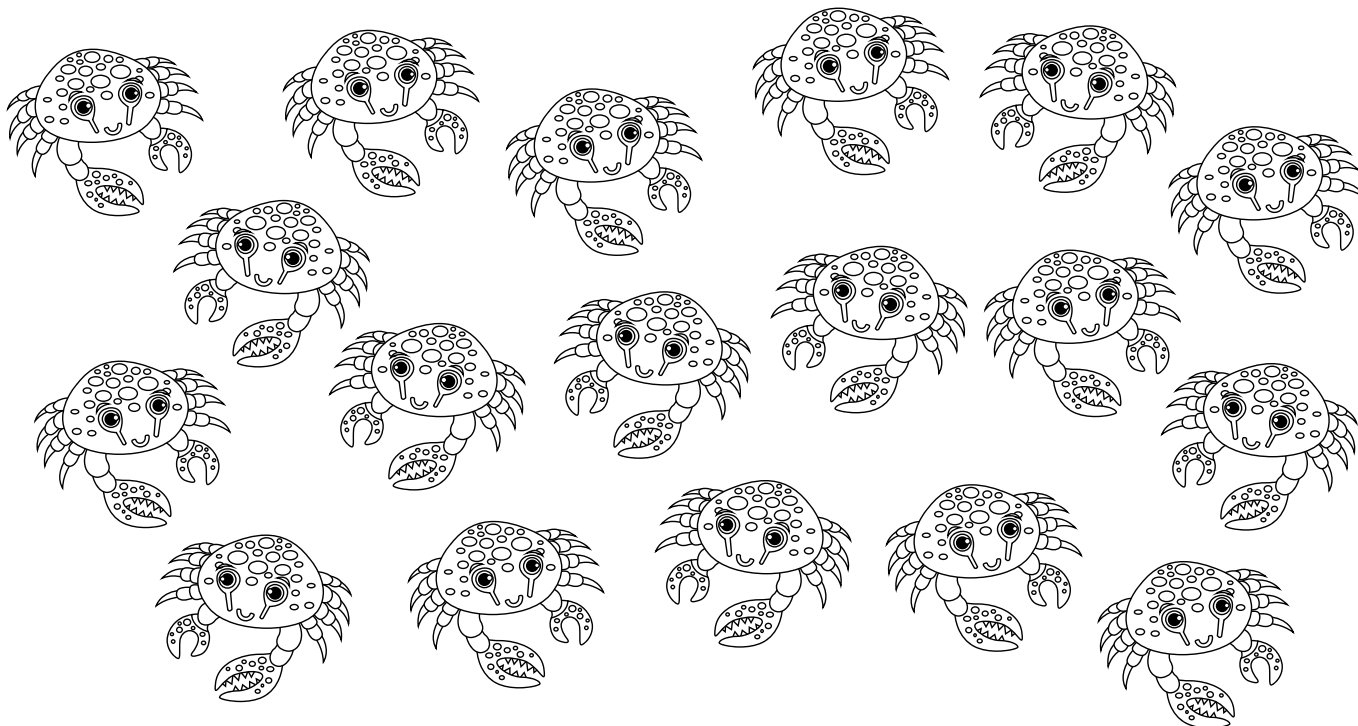

groups of 3 crabs = altogether

1 Order the numbers. Write them in the clouds.

2 Write one number before.

50 _____

41 _____

45 _____

43 _____

47 _____

48 _____

3 Write one number after.

45 _____

49 _____

40 _____

42 _____

46 _____

44 _____

1 Write
one more than.

47 _____

45 _____

42 _____

49 _____

one less than.

50 _____

44 _____

41 _____

48 _____

two more than.

43 _____

45 _____

50 _____

40 _____

two less than.

47 _____

50 _____

46 _____

43 _____

2 Write the number words from 40 to 50.

1 Read.

How can Waldo share 12 fish
equally between 2 bowls?

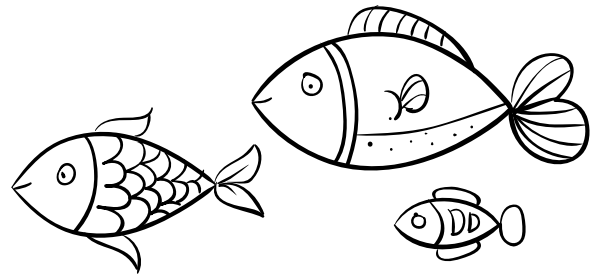

2 Underline the question. 3 Circle the facts.

4 Draw a picture to solve the problem.

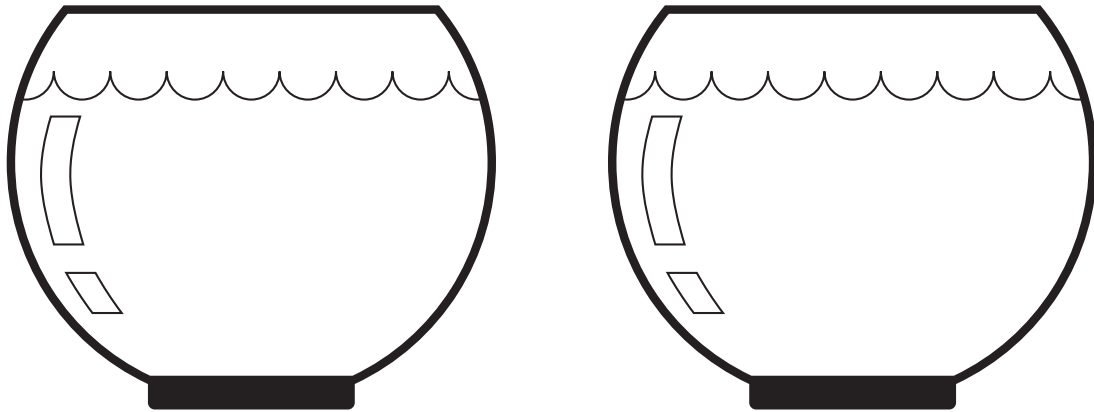

5 Waldo puts _____ fish in each bowl.

6 This time, Waldo shares 12 fish equally between 3 bowls.

Waldo puts _____ fish in each bowl.

7 What if Waldo had 4 bowls?

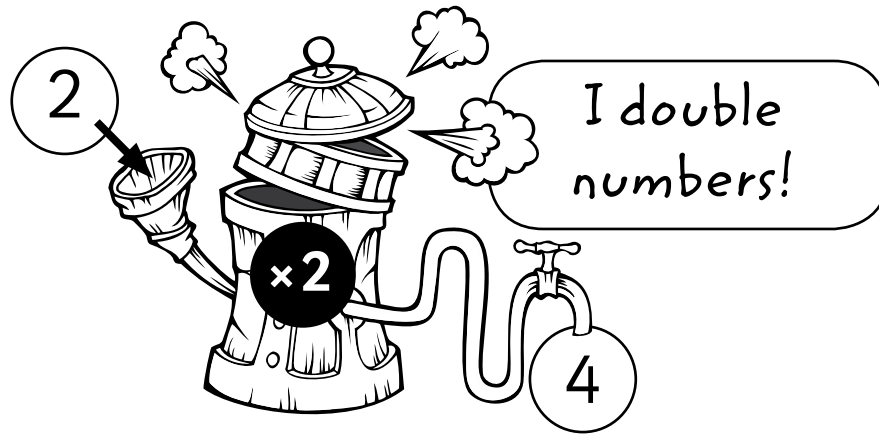

Write the answers.

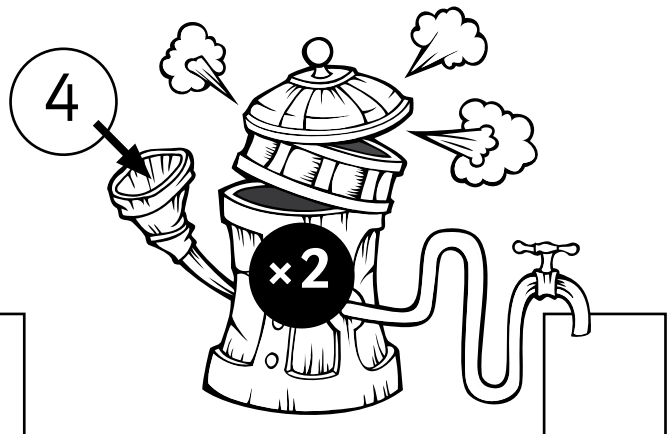
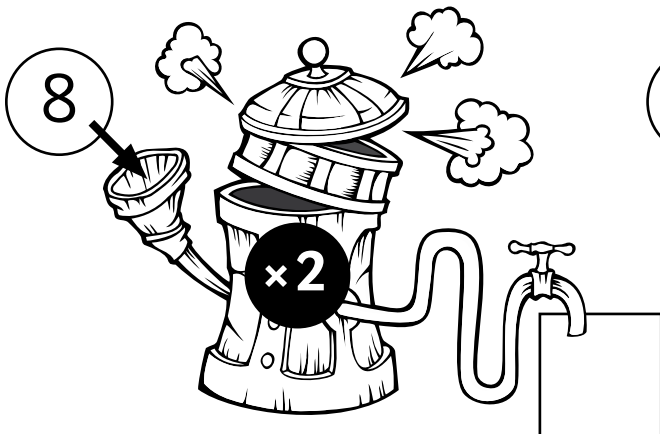
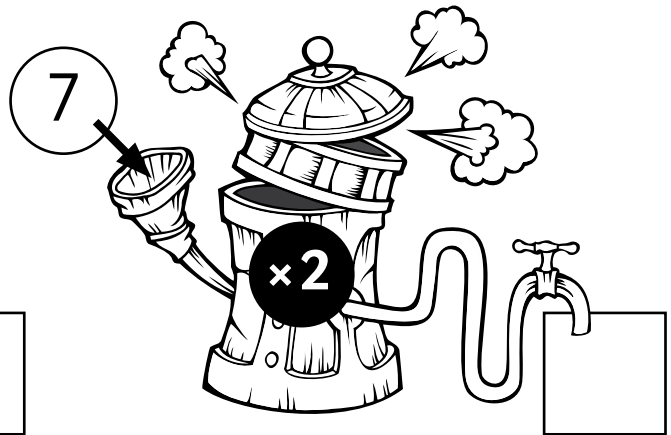
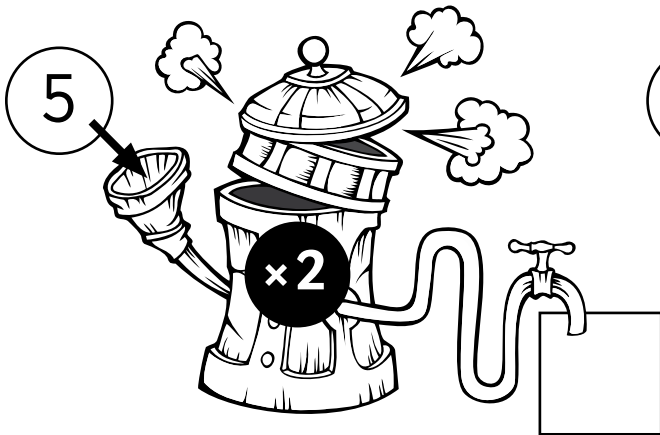
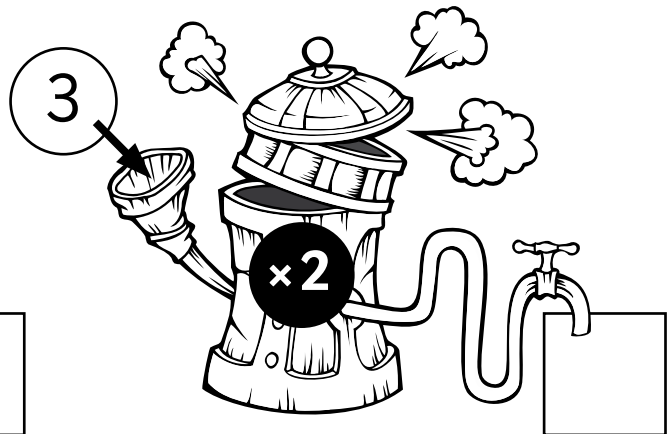
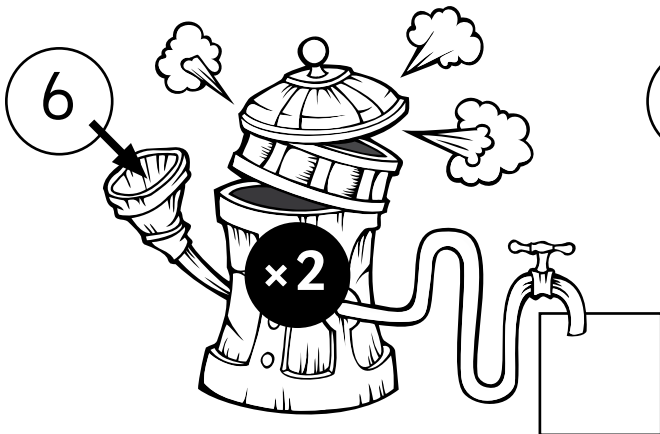

1 Read.

Dizzy tipped 47 pencils onto the table.

How would you organize the pencils to make them easier to count?

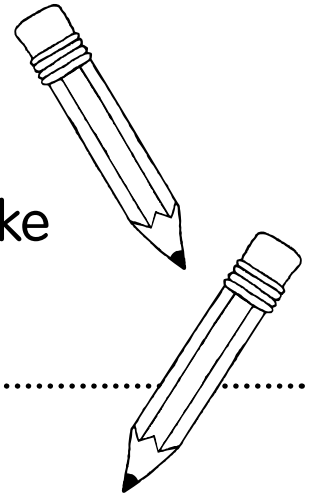

2 Underline the question. **3** Circle the facts.

4 Draw a picture.

5 Is there another way to organize items to make them easy to count?

You will need a balance scale (see below) and a bunch of toys.

- 1 Put a toy on one side of the scale.
- 2 Estimate which other toy will be the same weight. Put it on the scale.
- 3 Is the scale balanced? If not, try again with a different toy.
- 4 When you find a balanced pair of toys, put them aside and go again. You can make this into a game by taking turns weighing toys with a partner. Keep the toys that balance. The winner is the person with the most toys.

Make a Balance Scale

Materials: coat hanger, string or wool, ruler, 2 paper plates, hole punch, scissors

- 1 Cut six 30 cm lengths of string or wool.
- 2 Tie three strings to each end of the coat hanger.
- 3 Punch three holes evenly spaced around the rim of each plate.
- 4 Tie one plate to each set of three strings.
- 5 Hang the coat hanger from a chair or doorknob.
- 6 If the plates are not sitting flat, adjust the length of the strings.
- 7 If the plates are not balanced, slide one set of strings along the coat hanger.

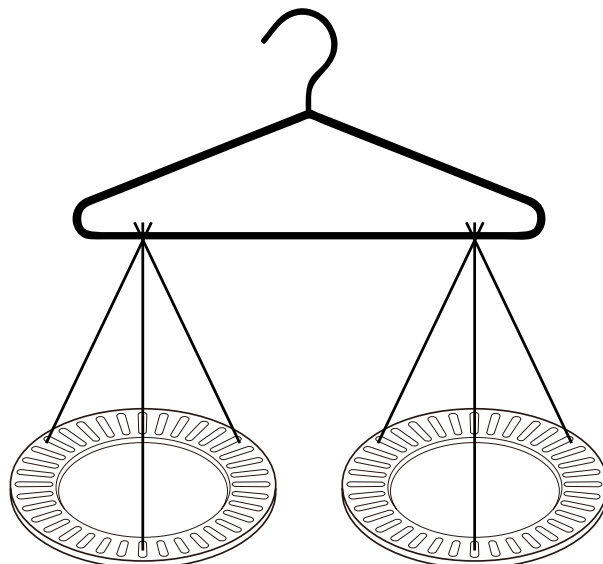

Woopee!

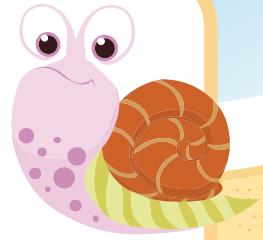

You're done
with Week 3!

